

Transfer Car With Multi-Strand Chain Conveyors

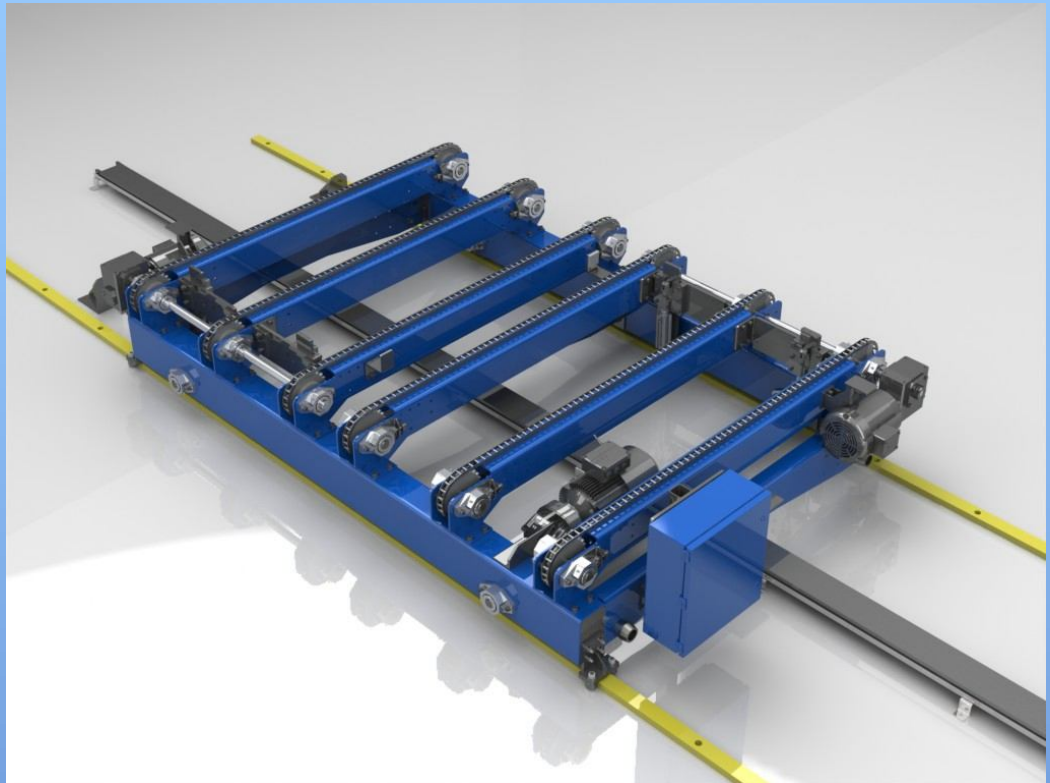

- $\frac{1}{4}$ " Formed steel and channel frame on all models
- 460 VAC power, 3 phase inverter duty motor
- #60 Chain for pallet weights in excess of 4000 lbs
- Heavy welded steel construction, epoxy painted
- 18" Standard height with bar stock rails
- Rigid formed and welded steel construction
- Transfer car speeds up to 200 FPM
- Hollow shaft gear motor (no need for a chain guard)
- Analog laser sensor for precise repeatable positioning
- PLC controlled with manual functionality

TEC Automation, Inc. 30 Hickory Springs Industrial Drive

Canton, GA. 30115 (770) 720-3333

www.tec-automation.com



TEC AUTOMATION, INC.

